

Volvo ECR35D, ECR40D in detail

Engine			
		ECR35D	ECR40D
Engine		Volvo D1.7A	Volvo D1.7A
Max. power at	r/min	2 200	2 200
Gross	kW	18,5	18,5
	hp	25,2	25,2
Gross power according to ISO 2534			
Max. torque	Nm	97	97
at engine speed	r/min	1 600	1 600
No. of cylinders		3	3
Displacement	cm ³	1 647	1 647
Bore	mm	87	87
Stroke	mm	92,4	92,4
Compression ratio		20,5	20,5
Electrical system			
		ECR35D	ECR40D
Voltage	V	12	12
Battery	V	1 x 12	1 x 12
Battery capacity	Ah	74	74
Alternator	V/Ah	12/60	12/60
Swing system			
		ECR35D	ECR40D
Max. slew speed	r/min	9	9
Max. slew torque	daNm	810	710
Undercarriage			
		ECR35D	ECR40D
Rubber track width	mm	300	300
Steel track width	mm	300	300
Bottom/top rollers per side		4/1	4/1
Track tension	by grease piston	by grease piston	by grease piston
Blade (width x height)	mm	1 780 x 368	1 780 x 368
Digging Performances			
		ECR35D	ECR40D
Standard bucket width (blade, W/O side cutter)	mm	600	600
Standard bucket mass	kg	90	90
Standard bucket rated capacity	l	114	114
Bucket rotation	°	198	199
Bucket breakout force (ISO)	daN	3 072	3 289
Short arm tearout force (ISO)	daN	2 066	2 371
With short arm	mm	1 250	1 400
Long arm tearout force (ISO)	daN	1 819	2 060
With long arm	mm	1 500	1 700

Weight and Ground Pressure			
		ECR35D	ECR40D
Operating weight according to ISO 6016	kg	3 520	3 880
Ground pressure (cab)	kPa	32,7	36
Ground pressure (canopy)	kPa	31,4	34,8
Transport weight	kg	3 445	3 805
With heated cab			
With direct-fit bucket			
With rubber tracks	mm	300	300
With short arm	mm	1 250	1 400
With fuel tank capacity	%	100	100
With thumb	+kg	64	64
With canopy	-kg	135	135
With extra counterweight	+kg	170	80
With long arm and additional counterweight	+kg	180	95
With steel tracks	+kg	130	130
Steel tracks	mm	300	300

Hydraulic system			
		ECR35D	ECR40D
Pump type		Variable displacement piston pump	
Maximum system flow	l/min	103	103
Maximum flow for accessories	l/min	65	65
Maximum pressure for accessories	MPa	22	22
Maximum flow for 2nd accessory circuit (option)	l/min	23	23
Maximum operating pressure	MPa	26	24

Travel System			
		ECR35D	ECR40D
Max. drawbar pull	daN	3 100	3 100
Max. travel speed low	km/h	2,7	2,7
Max. travel speed high	km/h	4,5	4,5
Gradeability	°	20	20

Service Refill			
		ECR35D	ECR40D
Fuel tank	l	64	64
Hydraulic system, total	l	62	62
Hydraulic tank	l	32	32
Engine oil	l	7	7
Engine coolant	l	7	7
Travel reduction unit	l	2 x 0,7	2 x 0,7

Sound Level			
		ECR35D	ECR40D
Interior sound level according to ISO 6396			
L _{pA}	dB	78	78
External sound level according to ISO 6395 and EU Noise Directive (2000/14/EC) and 474-1:2006 +A1:2009			
L _{WA}	dB	94	94

Specifications

LIFTING CAPACITY ECR35D

These capacities are given for a machine equipped with a cabin, 300mm rubber tracks and without a bucket or quick-coupler.

The below values are in compliance with ISO standard 10567. They do not exceed 75% of the tipping load or 87% of the hydraulic limit with the machine on firm level ground.

Loads marked with an asterisk (*) are limited by machine's hydraulic lifting capacity rather than tipping load.

Caution: In accordance with standard EN 474-5, the machine must be equipped to carry out handling operations.

It is the operator's obligation to know and follow the applicable national and local safety regulations.

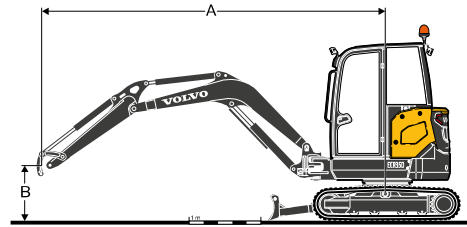

		Lifting point radius (A)									
		2.0 m		3.0 m		4.0 m		Max. reach		Max.	
Arm configuration	Lifting point height (B) m	kg		kg		kg		kg		m	
		Bucket	Quick-coupler	Bucket	Quick-coupler	Bucket	Quick-coupler	Bucket	Quick-coupler		
Arm: 1250mm + Dozer blade up	3	kg						479	470	3,95	
	2	kg		730	712	461	453	388	381	4,43	
	1	kg		669	652	440	432	359	353	4,57	
	0	kg		635	619	424	416	370	364	4,41	
	-1	kg	1 220	1 167	632	616			438	430	3,91
	-2	kg	1 268	1 213				753	732	2,76	
Arm: 1500mm + Additional counterweight + Dozer blade up	3	kg				537	526	485	475	4,23	
	2	kg				526	514	406	398	4,68	
	1	kg		766	744	502	491	379	371	4,81	
	0	kg	1 203*	1 203*	721	700	481	470	388	381	4,66
	-1	kg	1 364	1 300	712	691	476	465	448	438	4,19
	-2	kg	1 405	1 339	733	712		668	650	3,21	
Arm: 1250mm Dozer blade down	3	kg						760*	470	3,95	
	2	kg		901*	712	793*	453	750*	381	4,43	
	1	kg		1 368*	652	939*	432	805*	353	4,57	
	0	kg		1 628*	619	1 049*	416	918*	364	4,41	
	-1	kg	2 706*	1 167	1 570*	616			1 007*	430	3,91
	-2	kg	1 869*	1 213				1 101*	732	2,76	
Arm: 1500mm + Additional counterweight + Dozer blade down	3	kg				648*	526	643*	475	4,23	
	2	kg				713*	514	621*	398	4,68	
	1	kg		1 244*	744	877*	491	653*	371	4,81	
	0	kg	1 203*	1 203*	1 577*	700	1 018*	470	760*	381	4,66
	-1	kg	2 321*	1 300	1 603*	691	1 015*	465	927*	438	4,19
	-2	kg	2 320*	1 339	1 200*	712		1 037*	650	3,21	

LIFTING CAPACITY ECR40D

These capacities are given for a machine equipped with a cabin, 300mm rubber tracks and without a bucket or quick-coupler.

The below values are in compliance with ISO standard 10567. They do not exceed 75% of the tipping load or 87% of the hydraulic limit with the machine on firm level ground.

Loads marked with an asterisk (*) are limited by machine's hydraulic lifting capacity rather than tipping load.

Caution: In accordance with standard EN 474-5, the machine must be equipped to carry out handling operations.

It is the operator's obligation to know and follow the applicable national and local safety regulations.

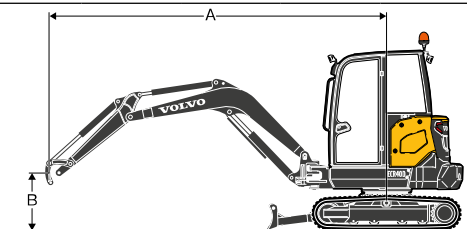

		Lifting point radius (A)									
		2.0 m		3.0 m		4.0 m		Max. reach		Max.	
Arm configuration	Lifting point height (B) m	kg		kg		kg		kg		m	
		Bucket	Quick-coupler	Bucket	Quick-coupler	Bucket	Quick-coupler	Bucket	Quick-coupler		
Arm: 1400mm + Dozer blade up	3	kg				609	579	544	517	4,27	
	2	kg		932	878	595	564	457	434	4,71	
	1	kg		864	812	569	539	428	407	4,84	
	0	kg		825	774	549	520	439	417	4,69	
	-1	kg	1 590	1 457	820	769	545	516	506	479	4,24
	-2	kg	1 630	1 495	842	791		745	702	3,27	
Arm: 1700mm + Additional counterweight + Dozer blade up	3	kg				617*	616	513	487	4,60	
	2	kg				629	596	439	417	5,00	
	1	kg		909	854	597	565	413	392	5,12	
	0	kg	1 122*	1 122*	856	802	571	539	420	398	4,99
	-1	kg	1 624	1 486	841	788	561	529	471	446	4,57
	-2	kg	1 657	1 517	855	802		631	596	3,73	
Arm: 1400mm Dozer blade down	3	kg				740*	579	786*	517	4,27	
	2	kg		957*	878	839*	564	837*	434	4,71	
	1	kg		1 542*	812	1 039*	539	901*	407	4,84	
	0	kg		1 884*	774	1 201*	520	982*	417	4,69	
	-1	kg	2 539*	1 457	1 885*	769	1 205*	516	1 088*	479	4,24
	-2	kg	2 757*	1 495	1 465*	791		1 240*	702	3,27	
Arm: 1700mm + Additional counterweight + Dozer blade down	3	kg				617*	616	713*	487	4,60	
	2	kg				733*	596	761*	417	5,00	
	1	kg		1 351*	854	950*	565	819*	392	5,12	
	0	kg	1 122*	1 122*	1 790*	802	1 145*	539	891*	398	4,99
	-1	kg	2 192*	1 486	1 892*	788	1 214*	529	987*	446	4,57
	-2	kg	3 181*	1 517	1 643*	802		1 121*	596	3,73	

Specifications

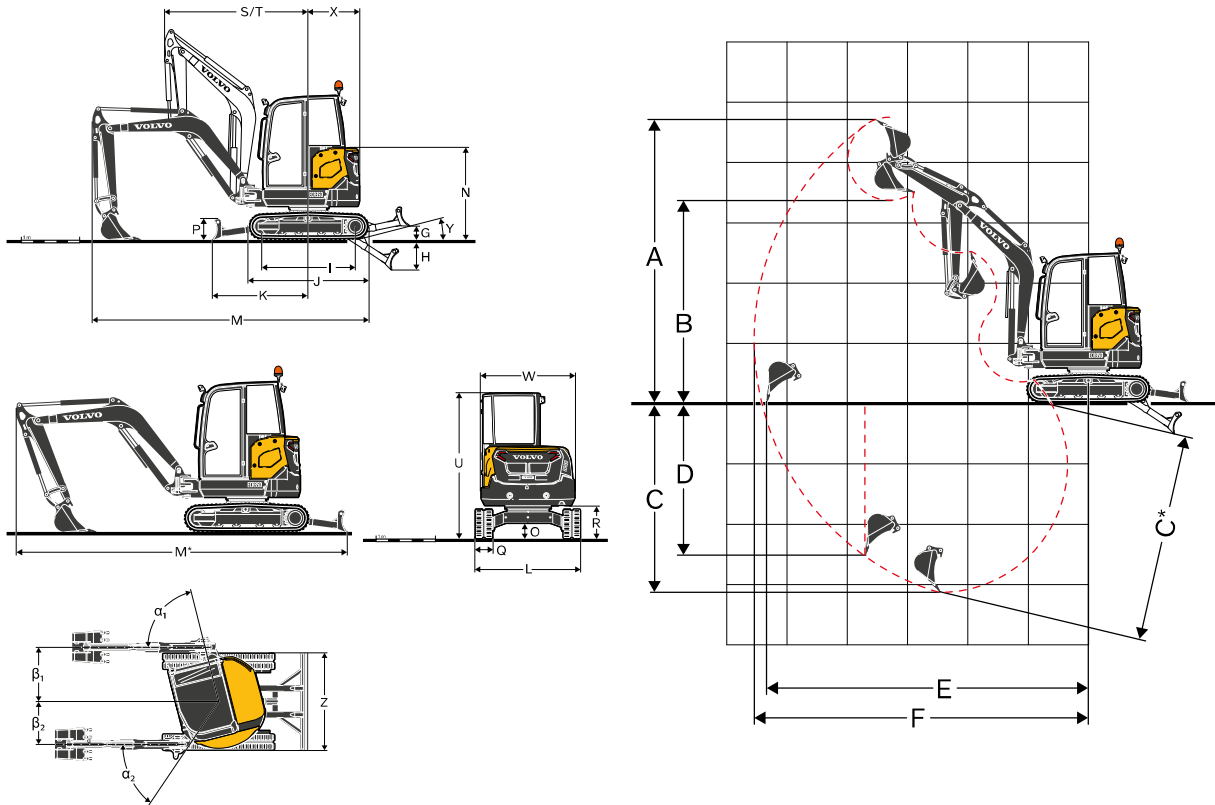

DIMENSIONS

Description		Unit	ECR35D	
			1250	1500
Arm				
A	Maximum cutting height	mm	4 497	4 640
B	Maximum dump height	mm	3 147	3 290
C	Digging depth	mm	2 785	3 035
C*	Maximum digging depth	mm	3 173	3 420
D	Maximum vertical wall digging depth	mm	2 251	2 494
E	Maximum digging reach at ground level	mm	5 131	5 370
F	Maximum digging reach	mm	5 261	5 497
G	Highest position dozer blade	mm		370
H	Lowest position dozer blade	mm		525
I	Tumbler length	mm		1 604
J	Track length	mm		2 055
K	Dozer blade, maximum reach at ground level	mm		1 648
L	Overall width with 300mm rubber tracks	mm		1 780
M	Overall length	mm	4 609	4 504
M*	Transport length	mm	5 435	5 380
N	Overall height of engine hood	mm		1 573
O	Minimum ground clearance	mm		285
P	Dozer blade height	mm		368
Q	Shoe width (rubber)	mm		300
R	Ground clearance to superstructure	mm		557
S	Front slew radius	mm	2 394	2 418
T	Front slew radius with maximum offset	mm	1 869	1 889
U	Overall height	mm		2 481
W	Overall width of superstructure	mm		1 575
X	Tail slew radius	mm	885	970
X'	Additional counterweight overhang	mm	85	(incl.)
Y	Angle of approach	°		25
Z	Dozer blade width	mm		1 780
α_1	Maximum boom swing angle to the left	deg		76
β_1	Maximum boom offset to the right	mm		995
α_2	Maximum boom swing angle to the right	°		56
β_2	Maximum boom offset to the left	mm		787

1: Option

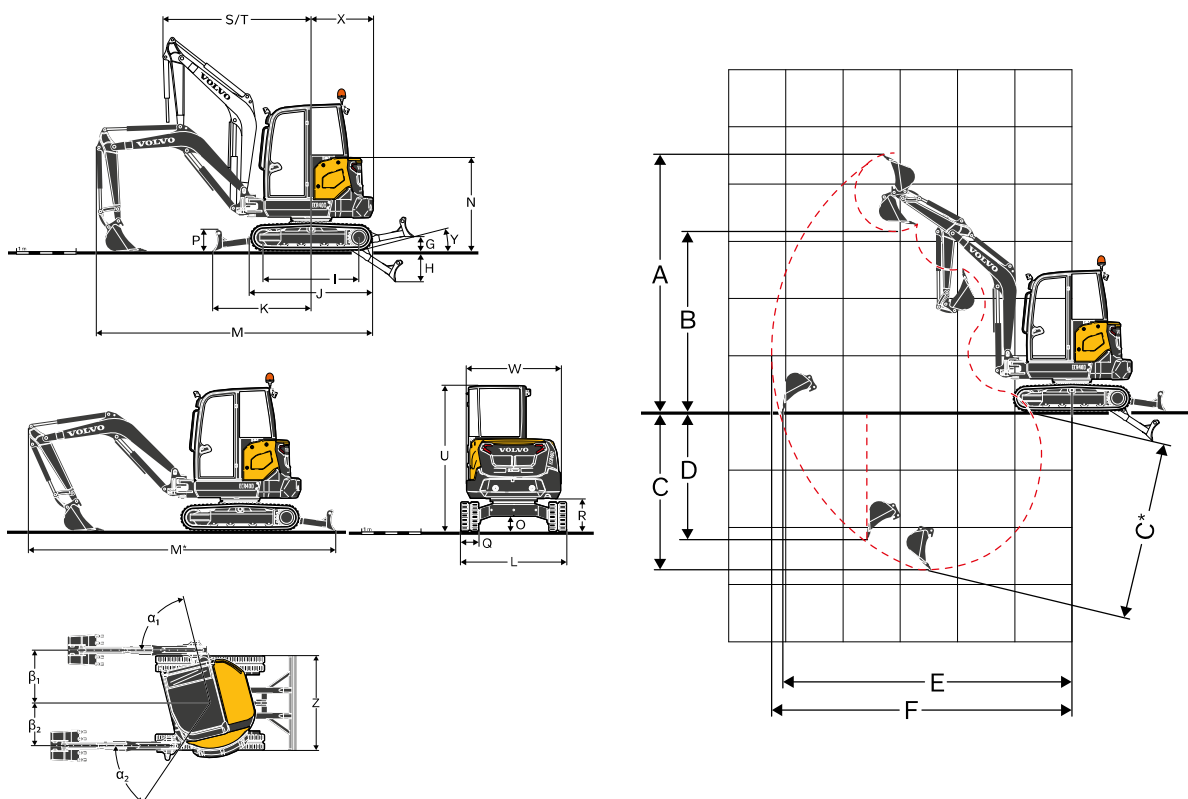

DIMENSIONS

Description	Unit	ECR40D	
		1400	1700
Arm	mm		
A	Maximum cutting height	4 690	4 853
B	Maximum dump height	3 347	3 514
C	Digging depth	3 131	3 431
C*	Maximum digging depth	3 481	3 771
D	Maximum vertical wall digging depth	2 521	2 811
E	Maximum digging reach at ground level	5 411	5 699
F	Maximum digging reach	5 533	5 813
G	Highest position dozer blade		370
H	Lowest position dozer blade		525
I	Tumbler length		1 604
J	Track length		2 055
K	Dozer blade, maximum reach at ground level		1 648
L	Overall width with 300mm rubber tracks		1 780
M	Overall length	4 780	4 640
M*	Transport length	5 650	5 580
N	Overall height of engine hood		1 573
O	Minimum ground clearance		285
P	Dozer blade height		368
Q	Shoe width (rubber)		300
R	Ground clearance to superstructure		557
S	Front slew radius	2 459	2 474
T	Front slew radius with maximum offset	1 923	1 936
U	Overall height		2 481
W	Overall width of superstructure		1 575
X	Tail slew radius	1 035	1 035
X'	Additional counterweight overhang	0	(incl.)
Y	Angle of approach	°	25
Z	Dozer blade width	mm	1 780
α_1	Maximum boom swing angle to the left	deg	76
β_1	Maximum boom offset to the right	mm	995
α_2	Maximum boom swing angle to the right	°	56
β_2	Maximum boom offset to the left	mm	787

1: Option